



Universal Sealants (U.K.) Ltd

BridgeCare A division of Universal Sealants (UK) Limited

Offering the complete service for bridge deck protection.

- 1 expansion joints
- 1 spray membranes
- 1 concrete repairs

StructureCare A division of Universal Sealants (UK) Limited

Supply and installation of expansion joints, protective coatings, concrete repairs and joint sealants to car parks, elevated structures and the construction industry.

International A division of Universal Sealants (UK) Limited

Supply and installation of bridge expansion joints and specialist construction products worldwide.

Nufins A division of Universal Sealants (UK) Limited

Manufacturers and suppliers of formulated products for civil engineering, construction, repair and refurbishment.

Head Office

Universal Sealants (U.K.) Ltd. Kingston House, 3 Walton Road, Pattinson North, Washington, Tyne & Wear, NE38 8QA, United Kingdom.

T: +44 (0)191 416 1530 F: +44 (0)191 415 4377 W: www.usluk.com E: info@usluk.com

Sales and Marketing

Universal Sealants (U.K.) Ltd. Blenheim Court, Newbold Road, Chesterfield, Derbyshire, S41 7PG, United Kingdom.

T: +44 (0)1246 207 000 F: +44 (0)1246 209 100 W: www.usluk.com E: info@usluk.com

North America

USL North America
Strategic partner of the
Geocel Corporation,
53280 Marina Drive,
Elkhart,
IN 46514

T: +1 800 348 7615
F: +1 800 348 7009
W: www.usluk.com
E: info@usluk.com

China

Panyu Chengzhu
Britflex Expansion Joints Ltd.
99 Wu Yang Nan Lu,
Wu Jin Town,
Xin Jin County,
Chengdu,
Sichuan Province,
611430
P.R.C.

T: +86 28 8251 1338
F: +86 28 8251 1498
W: www.usluk.com
E: info@usluk.com

Malaysia

USL Asia Pacific (M) SDN BHD
No.1, Jalan TPP 5/16,
Taman Perindustrian Puchong,
Seksyen 5,
47100 Puchong,
Selangor Darul Ehsan,
Malaysia.

T: +60 3 8061 4223
F: +60 3 8061 5223
W: www.usluk.com
E: uslmy@yahoo.com

Singapore

USL Asia Pacific PTE Ltd.
50 Tuas Crescent,
Singapore,
638730

T: +65 6863 6363
F: +65 6861 9566
W: www.usluk.com
E: uslasia@singnet.com.sg



FM 11022

APRIL/2004



C1/SfB
Z

TRANSFLEX BRIDGE JOINTS



BRIDGING THE GAP
WORLDWIDE



TRANSFLEX BRIDGE JOINTS

C1/SfB

Z

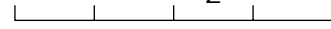

The product in brief

The Transflex system is registered with the UK Highways Agency, the Scottish Executive and the Welsh Assembly for use on highway bridge decks on all classes of roads and motorways. (BD 33/94: Joint Type 5 refers). The Transflex system is included in the UK Highways Agency list of approved products SA1. Britflex Resin Mortar is also included in SA1 as an approved material for transition strips to all types of expansion joint.

USL Transflex bridge joints comprise of steel angles and a steel bridging plate system encased in a flexible elastomer.

They are supplied in module lengths designed to be bolted to the structural concrete on either side of the expansion gap.

A range of models are available to accommodate movement up to 330mm, providing a substantially waterproof joint and a smooth running surface.

- Movement accommodation up to 330mm.
- Corrosive resistant elastomer casing.
- Accommodates skew movement.
- Factory vulcanised kerb and skew kerb units to special order.
- Membrane system available for maximum waterproofing.

Principle applications

- Highway bridge decks.
- Service Ramps.
- Multi - storey car parks.





TRANSFLEX BRIDGE JOINTS

C1/SfB

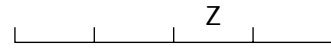

Design features

Transflex bridge joint 150, 200, 250 and 300

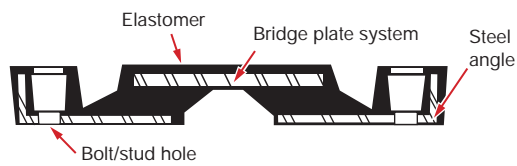



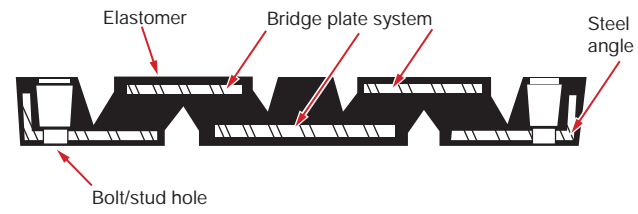

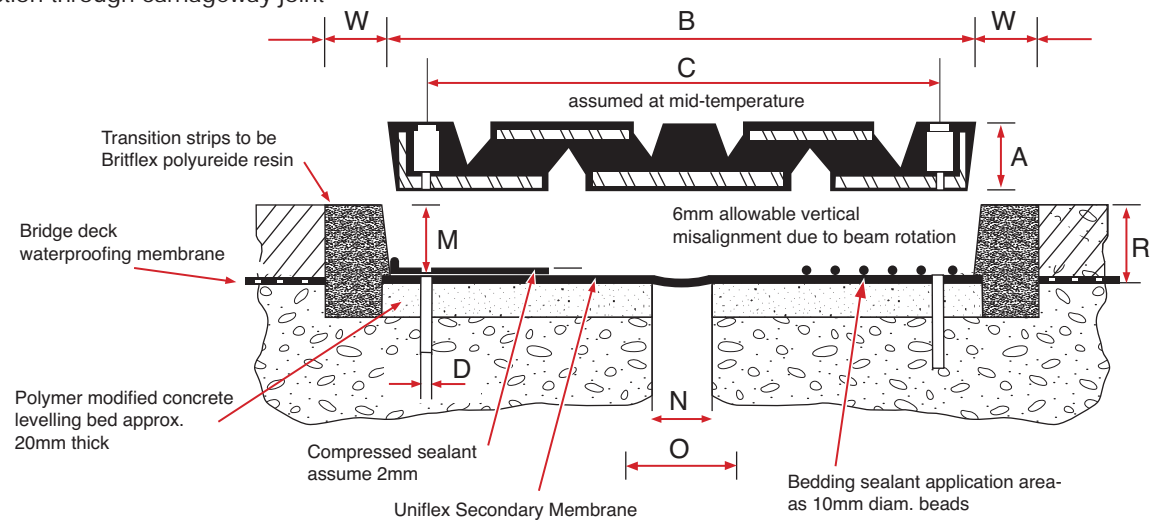

Transflex bridge joint 400, 650, 900 and 1300

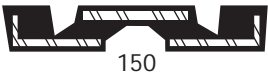

Typical cross section through carriageway joint



USL Transflex bridge joint models

Model	Movement accommodation	Module length	Module width	Module depth	Stud diam.	Module weight
			B	A	D	
 150	38mm	1750mm	240mm	35mm	12mm	30kg
 200	50mm	1830mm	274mm	40mm	12mm	48kg
 250	65mm	1830mm	356mm	46mm	16mm	68kg
 300	76mm	1830mm	432mm	52mm	20mm	88kg
 400	102mm	1830mm	590mm	54mm	20mm	150kg
 650	165mm	1830mm	724mm	75mm	24mm	272kg
 900	230mm	1830mm	890mm	93mm	24mm	375kg
 1300	330mm	1220mm	1204mm	127mm	30mm	451kg



TRANSFLEX BRIDGE JOINTS

C1/SfB

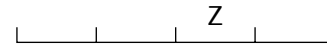

Design features

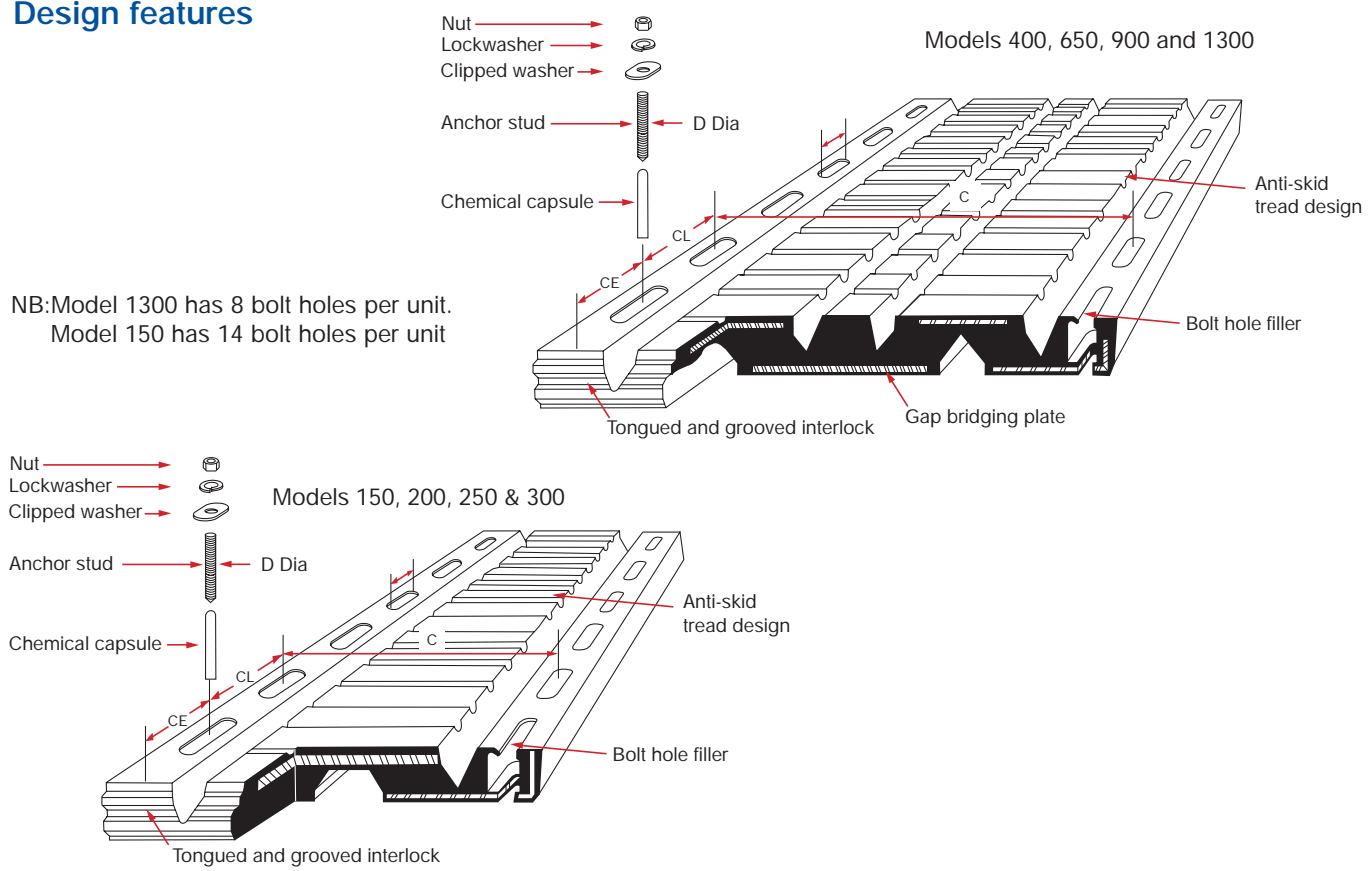

Max stud height above shelf	Bolt torque	Max joint width at mid-deck temp	Max joint width	Recess depth	Transition strip width	Bolt hole centres	Bolt hole centre along unit	End of unit to first bolt hole
M		N	O	R	W	C	CL	CE
32mm	38Nm	35mm	54mm	41mm	100mm	190mm	250mm	125mm
32mm	38Nm	51mm	76mm	46mm	100mm	220mm	305mm	152mm
40mm	95Nm	67mm	98mm	52mm	100mm	279mm	305mm	152mm
42mm	175Nm	83mm	121mm	58mm	100mm	342mm	305mm	152mm
42mm	175Nm	102mm	152mm	62mm	100mm	498mm	305mm	152mm
50mm	190Nm	121mm	203mm	81mm	125mm	618mm	305mm	152mm
60mm	275Nm	158mm	273mm	99mm	150mm	787mm	305mm	152mm
70mm	300Nm	216mm	381mm	133mm	175mm	1080mm	305mm	152mm

NOTE: Add 3mm to the recess depth 'R' when using the Uniflex secondary membrane.



TRANSFLEX BRIDGE JOINTS

C1/SfB

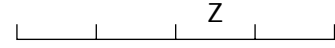

Description

The USL Transflex bridge joint system comprises of 8 No. standard models designed to accommodate movement up to 330mm by shear deformation of the elastomer between the steel components.

Each model incorporates steel angles designed to be bolted to the structural deck and a steel bridging plate system which spans the open joint gap.

The elastomer case is highly resistant to oils, solvent spillage and the trafficked surface includes an anti-skid pattern for safety having a rubber to rubber coefficient of static friction of 0.69. Each model is specifically designed to accommodate horizontal and skew movement and will also accommodate vertical movement due to rotation of up to 6mm.

Special steel clipped washers are provided with each unit, designed specifically for the Transflex joint. Stainless steel washers to the same high specification can be supplied to special order.

It is important that the correct washer is used in each case.

When additional waterproofing is specified a continuous length of Uniflex membrane should be bonded to the levelling bed with adhesive over the full width of the Transflex joint unit. Drain outlets will be incorporated.

Rebond profiles

During installation it is sometimes necessary, for practical reasons, to cut a Transflex unit on-site. In order to maintain the integrity of the joint between each module, male and female rebond profiles are available for each unit to reinstate the end configuration as required.

The profiles are available in lengths for cutting on-site together with an adhesive.

Factory vulcanised junctions

Special factory vulcanised junctions and kerb units are available to accommodate changes in level at kerbs and central reservations, in addition, standard units are capable of being modified on-site to accommodate some level changes.

Technical data – Materials

TECHNICAL SPECIFICATIONS		
PROPERTY	STANDARD	VALUE
Hardness	ASTM D2240	62 ± 5 Shore 'A'
Tensile strength (Min)	ASTM D412	130kg/cm ² min
Elongation at break (Min)	ASTM D412	400% min
Low temperature brittleness	ASTM D746	- 30°C (Not brittle)
Ozone resistance (After 48hrs. at 38°C exposure to 50 PPHM in air sample under 20% strain)	ASTM D1149	No cracks
Resistance to permanent set (24hrs. at 70°C)	ASTM D395	35% max
Oil resistance	ASTM D471	+18%

	REQUIREMENTS	TEST METHOD
Steel	Steel components manufactured to:	DIN 17-100 Type ST 37-2 ASTM Type A36

Steel clipped washers

Manufactured to DIN 37-2

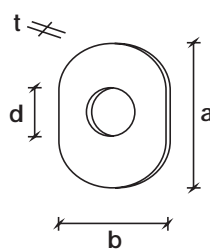

	a	b	d	t
150	34mm	27mm	14mm	3.0mm
200	34mm	27mm	14mm	3.0mm
250	45mm	35mm	17mm	3.7mm
300	60mm	50mm	21mm	4.0mm
400	60mm	50mm	21mm	4.0mm
650	65mm	55mm	25mm	4.5mm
900	72mm	51mm	25mm	6.0mm
1300	70mm	60mm	31mm	6.0mm



TRANSFLEX BRIDGE JOINTS

C1/SfB
Z

Technical data - Performance

Transflex bridge joints are designed to accept both horizontal and vertical loads due to traffic in accordance with the UK Highways Agency Technical Memorandum BD 33/94.

The graphs illustrated below are an indication of the horizontal load required to deflect each Transflex joint.

Technical data

Load/movement curves for USL Transflex bridge joints

Notation - = Compression
+ = Extension

Model
150

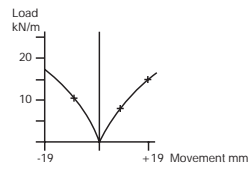

200

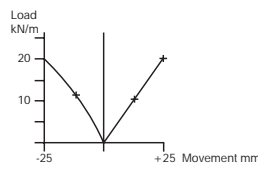

250

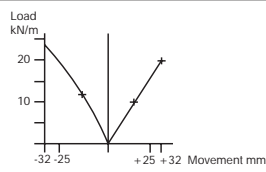

300

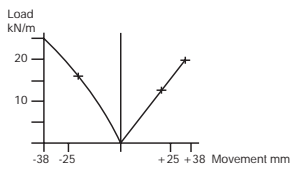

400

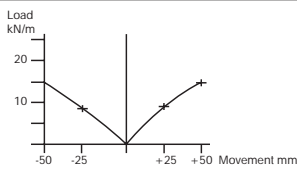

650

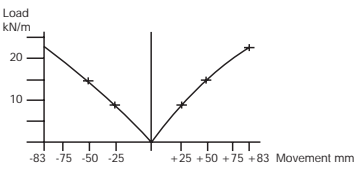

900

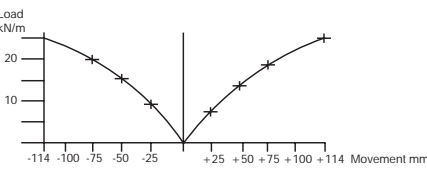

1300

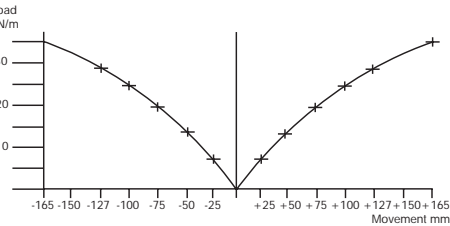



TRANSFLEX BRIDGE JOINTS

C1/SfB

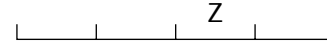

Factory vulcanised junctions

As part of a bridge joint installation scheme factory vulcanised junctions are available to accommodate the change in level at kerbs, footways and at the central reservation subject to special order and design detail.

The junctions available include kerb units, skew kerb units and change of level units, each factory vulcanised to maintain high quality standards and integrity of the seal.

Kerb upstand units

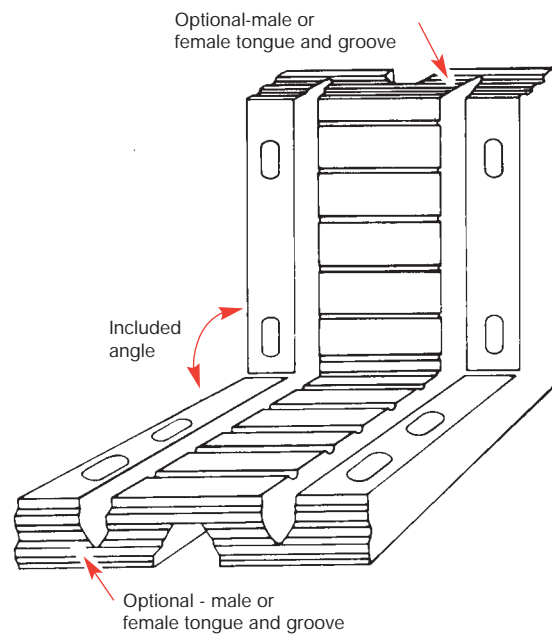

Examples of a factory vulcanised kerb unit for models 150, 200, 250 and 300

Skew kerb upstand units

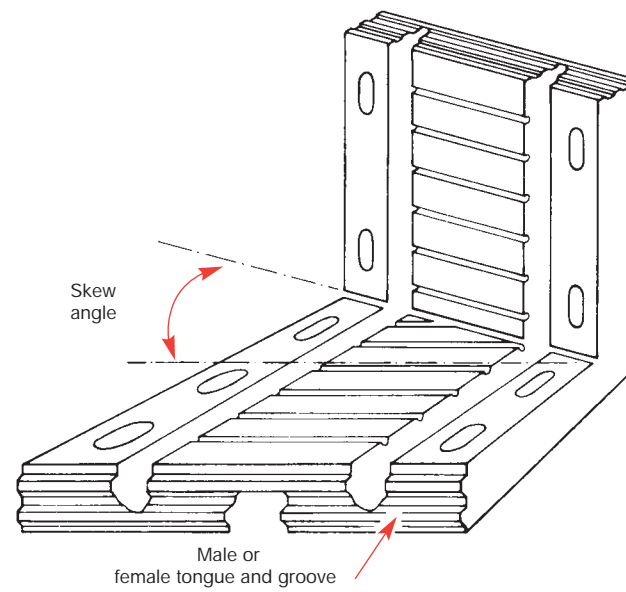

Examples of a factory vulcanised skew kerb upstand

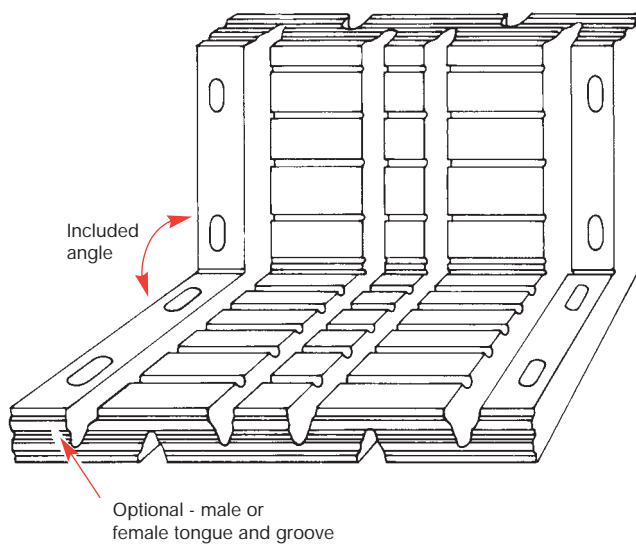

Examples of a factory vulcanised kerb unit for models 400, 650, 900 and 1300



TRANSFLEX BRIDGE JOINTS

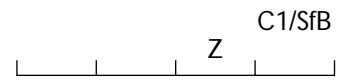

Kerb units

Change of level junctions are available factory vulcanised to meet the requirements for changing level from road deck to footway.

The junctions are fabricated such that the change in level from road to footway takes place behind the kerb line. Leg lengths, the included angles and the male or female end configurations should be specified at the time of order.

On-site modification to standard units

Whilst factory vulcanised change of level junctions should be used as far as possible it may be necessary to modify standard units on-site to accommodate changes of level from road to footway.

This is achieved by cutting and notching the steel bridging system and steel angles and bending the units through 30°. The point of change of level from road to footway taking place behind the kerb line. The void in the kerb line being protected with a galvanised steel cover plate.

Details on change of level modifications available from Universal Sealants (UK) Ltd.

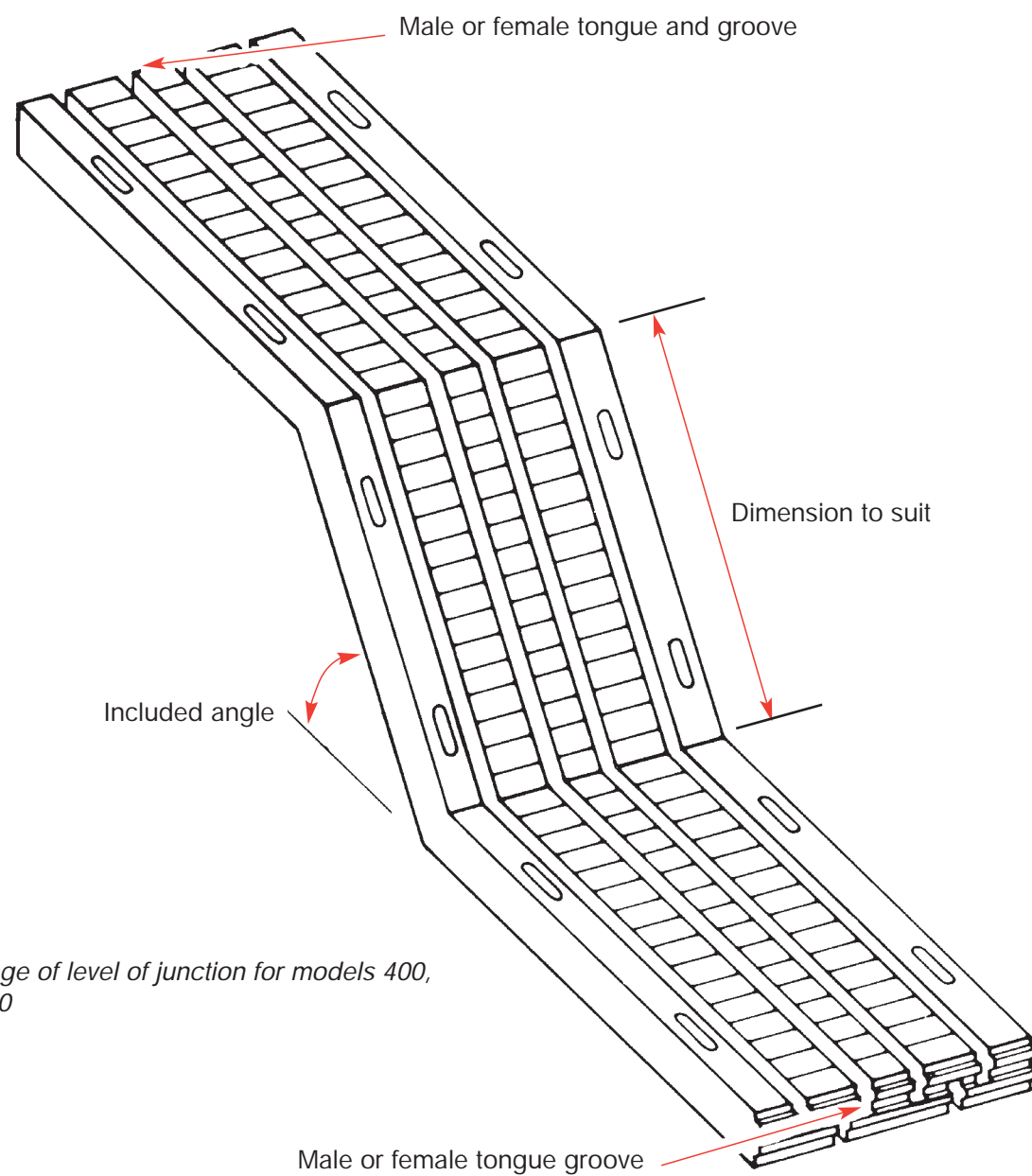

Examples of change of level of junction for models 400, 650, 900 and 1300



TRANSFLEX BRIDGE JOINTS

C1/SfB

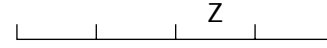

Transflex temperature adjustment guide

It will often be necessary to pre-compress or pre-extend the Transflex joint to pre-set the joint unit to suit the relative position of the structural expansion joint in the bridge deck.

At the time of installation therefore knowing the mean deck temperature range and the movement to be accommodated, the amount of pre-compression or pre-extension can be taken off a graph prepared in the manner of the example illustrated.

- NB:**
1. Example based on model 200 (274mm wide).
 2. The example assumes a total design movement accommodation requirement of + and - 25mm from the mid point position.
 3. The installation temperature requires that the joint be compressed to 254mm overall width - prior to installation.

4. Hence the new bolt hole centres "C" to be drilled in the structural concrete will be 199mm instead of 219mm.
5. Maximum movement of joint module + and - 25mm.
6. Actual movement required + and - 25mm.

Key:

- a** Maximum compression
 $274 - 25 = 249\text{mm}$
- b** Compressed width for installation
254mm
- c** Actual module width 274mm
- d** Maximum extension
 $274 + 25 = 299\text{mm}$

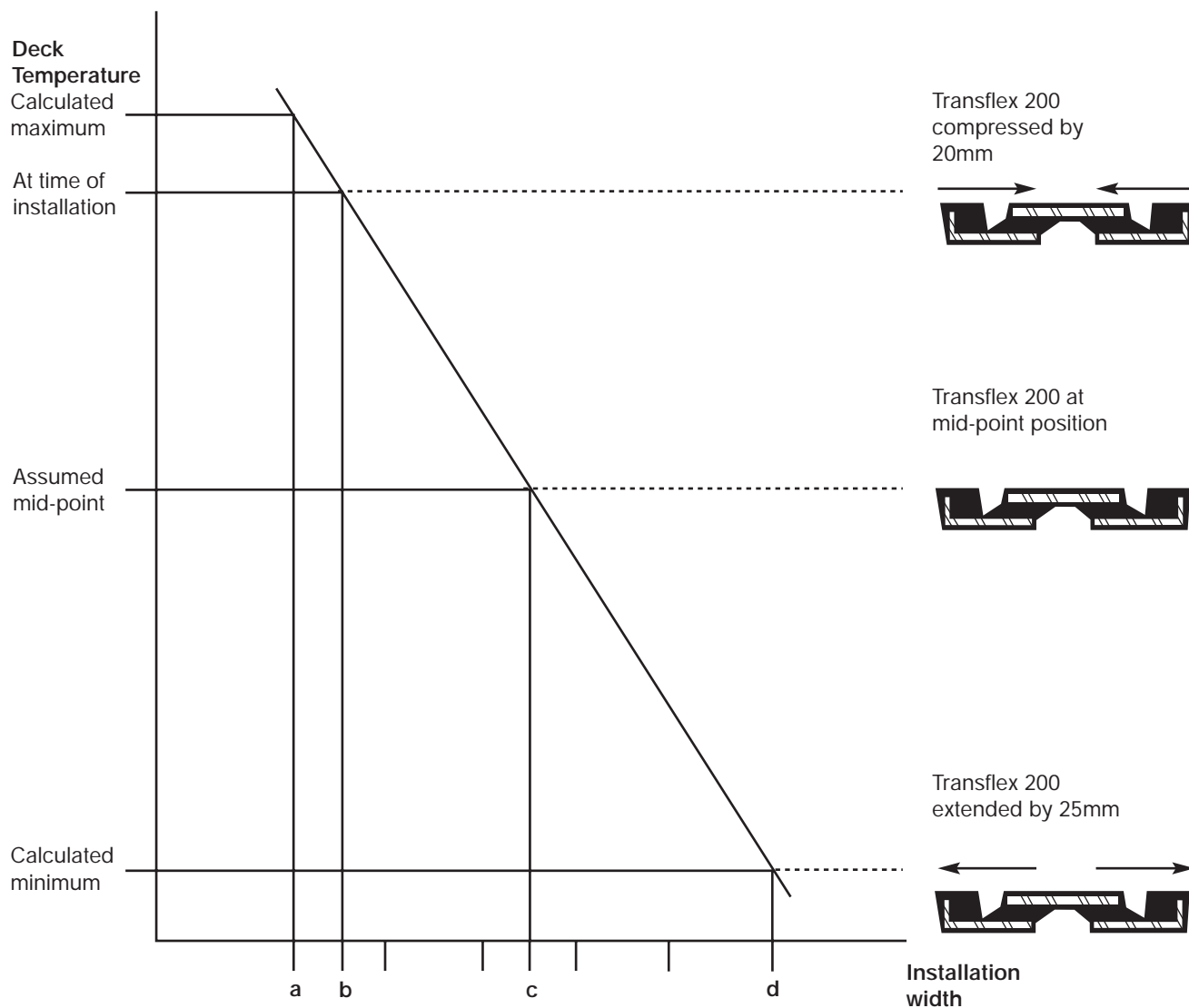



TRANSFLEX BRIDGE JOINTS

C1/SfB

Z

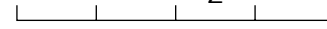

Site installation – for concrete decks

A flat and level monolithic haunch or recess should be formed in the structural deck to accommodate the Transflex joint and the transition strips.

At the design stage care should be taken to locate the reinforcement avoiding the position of the bridge joint anchor studs.

In the interest of achieving a smooth traffic ride over the joint, the wearing course should be machine laid continuously over the structural joint and subsequently removed just prior to installing the bridge joint.

The removal of the surfacing over the joint in the deck is facilitated by the location of a plywood bond breaker of a width just under the combined width of the joint and the transition strips prior to the surfacing being laid.

At the time of installation dependent upon mean deck temperature it may be necessary to pre-compress or pre-extend the Transflex joint unit to suit the relative position of the structural expansion joint in the bridge deck.

The installation width of the joint may be determined using graphical means illustrated in the example under the heading "Temperature Adjustment Guide". Once the Transflex module installation width and the new bolt hole centres have been determined the joint module can be adjusted in width accordingly.

The surfacing may then be sawn and removed to the dimension equivalent to the installation width of the joint plus the two transition strips.

The exposed concrete should be scabbled and the final level of the bed adjusted using a polymer modified screed approximately 20mm thick maintaining the recess depth "R" ie 46mm in the case of model 200.

The bridge joint modules centred over the expansion joint in the deck may then be used as templates for the pilot holes thus determining the final position of the bolt holes or by use of a prepared template.

The final bolt holes should be drilled and studs installed using chemical fixing anchors. Each bridge joint unit may then be laid into position over the studs on beads of bedding sealant. The plain clipped washers supplied with each unit are then located, and the assembly bolted down.

Subsequent modules should then be located and fixed in the same way, the sealant first being applied to the tongue and groove edges of each unit prior to jacking into position to ensure a substantially waterproof junction.

The fixing nuts should be torqued to the rate indicated for each model and the polyureide resin transition strips laid level with the wearing surface but finished slightly higher (3mm) than that of the top of the bridge joint module.

Following final torque checks on the fixing nut, the bolt holes should be filled with Transflex Bolt Hole Sealant to protect the stud against corrosion.

Waterproof installations

For improved waterproofing it is necessary to incorporate Uniflex Secondary Membrane which should be fixed with epoxy adhesive to the top surface of the levelling screed over the full width of the Transflex Unit prior to the sealant bedding application. The recess depth R should be adjusted by +3mm.

Further information

1. USL Transflex Installation Manual

The detailed Installation Guide sets out the recommended installation procedure for Transflex bridge joints.

2. USL Transflex Product Schedules

Detailed product schedules for each joint module sets out the components available against each Transflex model type.

Ancillary materials and equipment

Materials:

Studs

{ See chart under the heading "Description for recommended diameter and type"

Chemical fixing anchors

Uniflex membrane for waterproof applications.

Uniseal 120, one part polysulphide for bedding and sealing each module.

Transflex Bolt Hole Sealant for filling bolt holes.

Transflex Levelling Screed polymer modified mortar for use as a levelling screed or bed.

Britflex polyureide resin for forming transition strips between road wearing surfaces and the module joint.

Equipment:

Extension/compression tool for adjusting and pre-setting the module joint to suit temperature/joint gap at time of installation.

Rotary percussion drill • Forced action mixer • 'G' Gun • Torque spanner • Jacking equipment.

Health and safety

USL Transflex

There are no health hazards associated with USL Transflex in normal use.

Ancillary materials

Health and safety data sheets for Uniseal 120, Transflex Bolt Hole Sealant, Transflex Levelling Screed are available separately from USL's Technical Service Department.

Important note

Whilst all reasonable care is taken in compiling technical data on the company's products all recommendations or suggestions regarding the use of such products are made without guarantee since the conditions of use are beyond the control of the company. It is the customer's responsibility to satisfy himself that each product is fit for the purpose for which he intends to use it and that the actual conditions of use are suitable.